

Specification
of
Photovoltaic module

Type KC21T02

Aug. 3, 2007

Prepared by *P. Matsumoto*

Checked by *J. Hirota*

Checked by *H. Yamamoto*

Approved by *M. Yamashita*

Kyocera Corporation

Kyoto, Japan

Specification of photovoltaic module

1. Application

This specification is applicable for a photovoltaic module KC21T02.

This module is approved by IEC 61215.

2. Electrical specification

Maximum power	(Pmax)	21 W + 1.5 %, - 5 %
Short circuit current	(Isc)	1.30 A
Open circuit voltage	(Voc)	21.7 V
Maximum power current	(Ipmax)	1.21 A
Maximum power voltage	(Vpmax)	17.4 V
Standard test condition (STC)		Cell temperature 25 °C Spectrum AM1.5 Irradiance 1 kW/m ²

Testing standards of Kyocera are valid at the date of manufacture of the PV Module(s). Kyocera's calibration standards shall be compliant with the standards applied by international institutions accredited for this purpose.

3. Physical specification

Product No.	AC-563040
Drawing No.	AC-566379
Outside dimensions	367 × 512 × 17 mm
Weight	2.0 kg

4. Environmental specification

Wind pressure resistance	Front side or back side of the photovoltaic module is less than 2400 Pa when the installation conditions of (A) or (B) of "Figure 1" are applied.
Operating temperature (Cell temperature)	-40 °C to 90 °C
Local limit	<ul style="list-style-type: none"> • An area where there is no exposure to corrosive gases. • An area where there is no direct exposure to seawater. • An area where snow load is less than 2400 Pa, when the installation conditions of (A) or (B) of "Figure 1" are applied.

5. Terms of use

- ① Do not use this module for any purpose except a photovoltaic system.
- ② This module cannot be used as a roofing material.
- ③ This module does not have fire prevention and waterproofing attributes.
- ④ Never use any concentration device because it may break the module.
- ⑤ No blocking diode is installed in this module. Please perform prevention measures for reverse current to the module with equipment, such as a blocking diode or a charge controller.

6. Installation

- ① When choosing a site, avoid trees, buildings or obstructions, which could shadow the modules, especially during the winter months when the height of the sun is lowest in the year.
- ② Fix installation holes by screws and install solar module by supporting four sides' frames. (Refer to "Figure 1".) Attach four sides' frames to installation plate and fix four installation holes by screws, like (A) and (B). Do not install solar module like (C) and (D). For (A) or (B), prepare a frame which has strength of 2400Pa or more.
- ③ Although the anodized aluminum processing is applied to the frame of this module, in a corrosive environment, galvanic corrosion due to contact with a different kind of metal may occur on rare occasions between the frame and another material. In that case, take measures to prevent corrosion.
- ④ As an example to prevent galvanic corrosion, we recommend using washers made of resin between the module frame and the mounting structure.
When an effective installation is possible additionally, it is not the one to stick to it.
- ⑤ When the module is installed, use stainless M4 bolts or M4 bind screws.
- ⑥ The solar modules should be tilted for optimum winter performance.
Refer to the recommended module tilt angle table for your site.
(Refer to "Table 1" and "Figure 2".)
- ⑦ Do not step on the module to prevent damage.
- ⑧ Do not drop the module or strike the module with a tool.

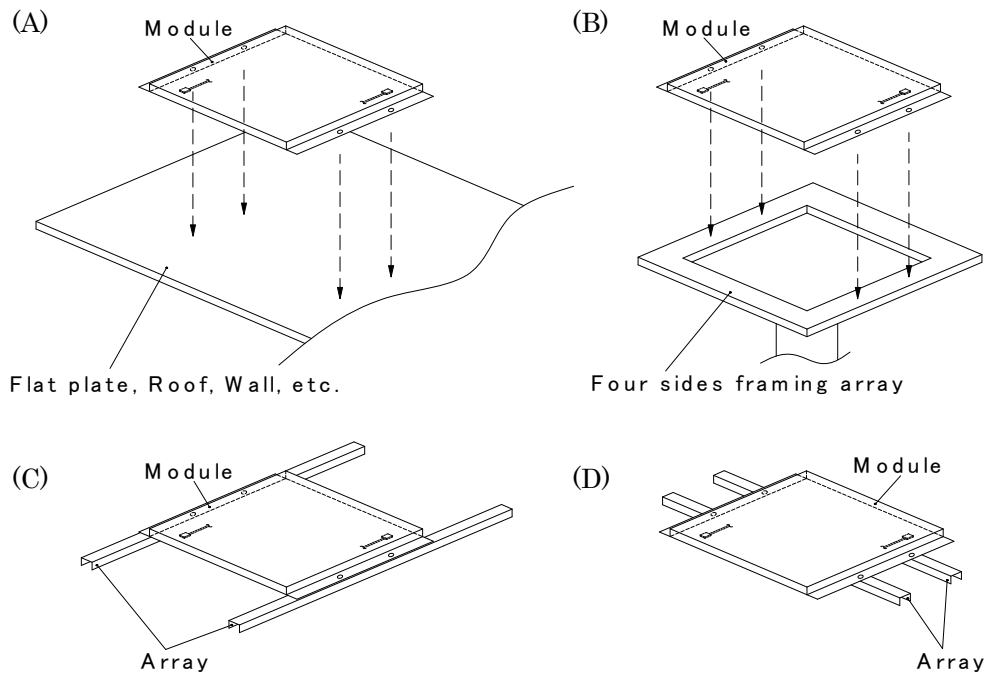

Figure 1

Site Latitude in Degree	Fixed Tilt Angle
0 to 15	15°
15 to 25	Same as latitude
25 to 30	Latitude +5°
30 to 35	Latitude +10°
35 to 40	Latitude +15°
40 +	Latitude +20°

Table 1

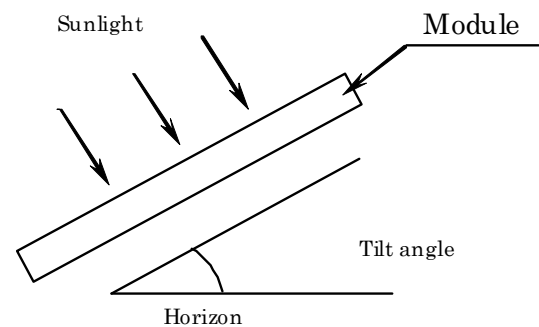
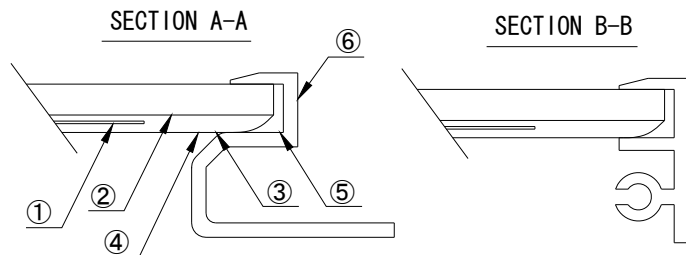

Figure 2

7. Remarks

- ① Keep the module in ventilated condition, away from high temperature and high humidity environment.
- ② Do not put, attach or contact anything on the back sheet of the module because it may damage the back sheet.
- ③ While the module is operating, or when a load is applied, please do not connect or disconnect the output cable.
- ④ Be careful not to damage the cable. In addition, do not pull the cable with strength of 20N or more.
- ⑤ Do not step on the module to prevent damage under any circumstances.



No.	DESCRIPTION	QT.	MTL.	REMARKS	No.	DESCRIPTION	QT.	MTL.	REMARKS
①	SOLAR CELL	36	Si	RSC150SF-TB1/6 d. Blue CELL	⑥	FRAME	1 S.	Al	-
②	GLASS	1	-	LOW-IRON TEMPERED	⑦	JUNCTION BOX	2	PPE	-
③	POTTANT	1 S.	EVA	-	⑧	CABLE	2	-	(+) WHITE 500mm (-) BLACK 500mm
④	BACK SHEET	1	PET	WEATHER-RESISTANT	⑨	LABEL	1	PET	-
⑤	BUTYL	1 S.	-	-	⑩	T. P. SCREW	4	SUS	-

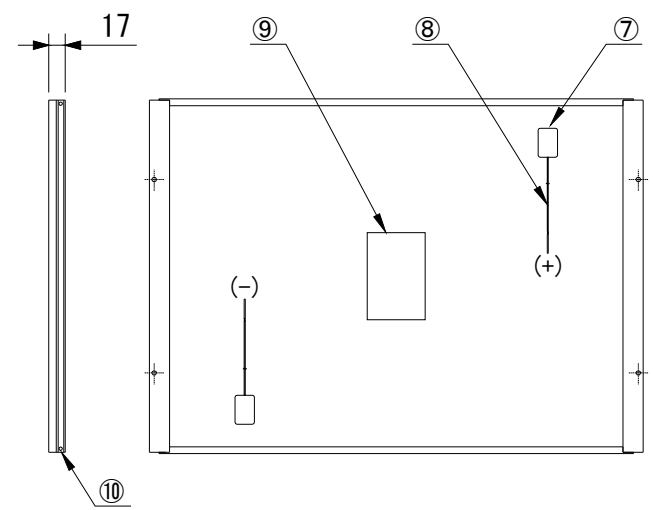
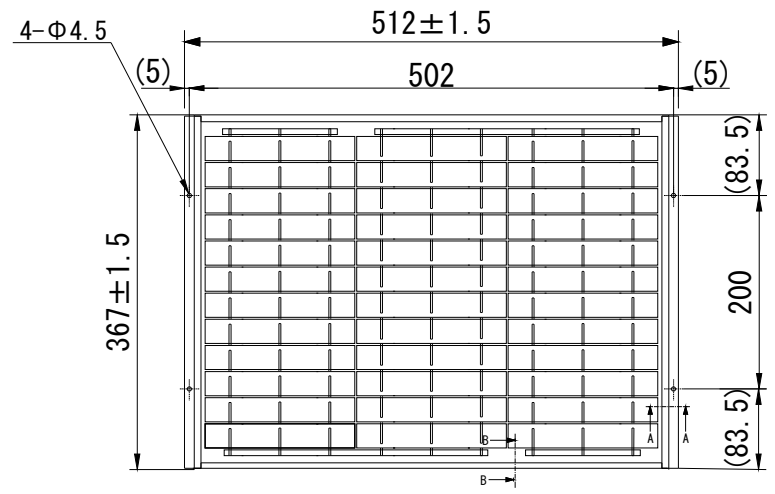

DIMENSION	TOLERANCE
~ 6	0.3
6 ~ 30	0.5
30 ~ 120	0.8
120 ~ 315	1.2
315 ~ 1000	2.0
1000 ~	2.5

SCALE FREE	NAME PHOTOVOLTAIC MODULE
TOLERANCE REFER TO TOLERANCE LIST	
DATE 2007. 8. 3	TYPE KC21T02
	DWG. NO. AC-566379

KSS-700-565 (5/5)